

ProAir 2200

Process Air Compressed Airline Monitor



PRODUCT HIGHLIGHTS

- **Continuous real-time gas monitoring of compressed airlines**
- **Can be custom configured with up to 4 sensors**
- **Able to withstand harsh process environments**
- **User programmable alarms and relays**
- **Meets Grade D breathing and NFPA 99 requirements**
- **Low flow alarm**
- **Field replaceable sensors**

ProAir 2200 is a compact, easy to install and operate compressed airline monitor that can continuously and simultaneously monitor up to four gases in real-time using internally mounted sensors. ProAir 2200 can be custom configured to monitor a variety of hazardous gases present in compressed air, including carbon monoxide, oxygen, dew point, carbon dioxide, VOCs, trace hydrocarbons and many other gases associated with OSHA monitoring requirements for Grade D breathing air.

ProAir 2200 has a user-friendly software interface and is operated by using push buttons and LCD display. The general instrument set-up configuration and maintenance functions are password protected to prevent unauthorized personnel from gaining access to secure data. The maintenance and operation menu functions allow the user to change alarm points, program relays and perform calibrations in the field. The monitor uses a backlit digital display, a power LED and a fault LED indicator, integrated audible and visual alarms with

two alarm threshold indicators and features a four minute audio defeat option for alerts below alarm level maximum. The sample inlet pressure must be regulated to 55 psi. It has an integral electronic flow sensor with a fault alarm to monitor for low flow conditions of less than 0.2 liter per minute.

ProAir 2200 is ENMET's most advanced compressed airline monitor for process or breathing air requirements. It is used in a wide variety of industrial applications from aerospace to pharmaceutical and can be easily adapted to meet your specific needs for compressed airline monitoring.

For additional information on how to order your ProAir 2200, contact the ENMET sales department today. Please let us know the gases you would like to monitor along with the ranges and alarm points and then we will custom design a ProAir 2200 for your monitoring application.

ProAir 2200

GENERAL SPECIFICATIONS

Display:	High-contrast, backlit
Alarms:	Visual: LEDs Audible: Piezoelectric horn, 95 dB at 2 feet
Alarm Relays:	5 programmable gas relays plus fault. All relays are programmable latching or non-latching, dry SPDT, 10 amps (resistive load only) at 110 VAC.
Operating Power:	100 to 240 VAC and/or 12 VDC, 15 Watts
Inputs/Outputs:	Analog: 4-20 mA Digital: RS-232 and RS-485 Modbus
Inlet Pressure:	Must be regulated to 55 psi (user provided)
Flow Rate:	0.5 liter per minute (1 SCFH)
Enclosure:	Thermoplastic box with clear, hinged front cover, designed for NEMA 12 and 4X
Dimensions:	9.3 W x 11.9 H x 6.1 D inches (23.5 W x 30.3 H x 15.4 D cm)
Weight:	8 lbs. (3.6 kg.)
Approvals:	UL 60601-1, IEC 60601-1 & CSA 22.2, No. 601.1

DIMENSIONS

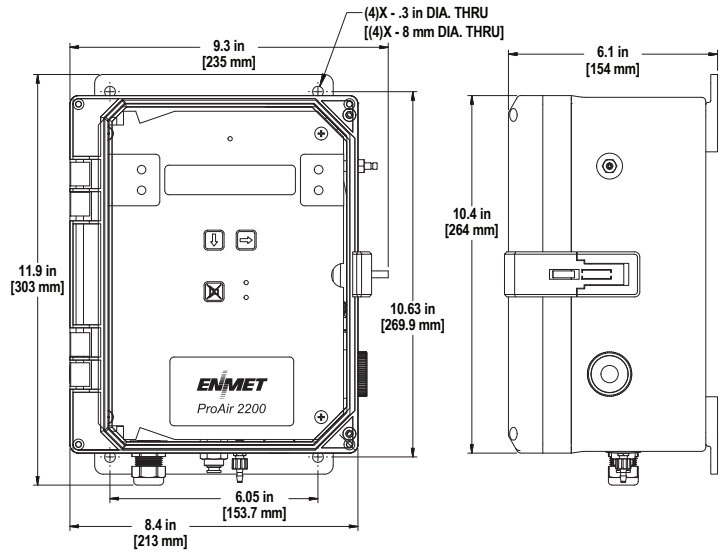

ORDERING INFORMATION

Use the gas chart below to select your custom gas monitoring configuration. Please contact the ENMET sales department and let us know the gases you would like to monitor along with the ranges and alarm points and then we will design a ProAir 2200 for your specific gas detection requirements.

GASES MONITORED*

- | | | | |
|---|--|--|---|
| • Acetaldehyde, CH ₃ CHO | • Ethyl alcohol, C ₂ H ₅ OH | • Jet Fuel, JP-8 | • Pentane, C ₅ H ₁₂ |
| • Acetone, (CH ₃) ₂ CO | • Ethylene, C ₂ H ₄ | • Kerosene | • Propane, C ₃ H ₈ |
| • Acetonitrile, CH ₃ CN | • Ethylene oxide (ETO), C ₂ H ₄ O | • Methane, CH ₄ | • Propylene, C ₃ H ₆ |
| • Ammonia, NH ₃ | • Fluorine, F ₂ | • Methanol, CH ₃ OH | • Propylene oxide, C ₃ H ₆ O |
| • Benzene, C ₆ H ₆ | • Gasoline | • Methyl alcohol, CH ₃ OH | • Solvents |
| • Bromine, Br ₂ | • Heptane, C ₇ H ₁₆ | • Methyl chloride, CH ₃ Cl | • Styrene, C ₈ H ₈ |
| • Butane, C ₄ H ₁₀ | • Hexane, C ₆ H ₁₄ | • Methyl ethyl ketone (MEK), C ₄ H ₈ O | • Sulfur dioxide, SO ₂ |
| • 2-Butanone (MEK), C ₄ H ₈ O | • Hydrocarbons | • Methylene chloride, CH ₂ Cl ₂ | • Toluene, C ₇ H ₈ |
| • Carbon dioxide, CO ₂ | • Hydrogen, H ₂ | • Natural Gas | • Trichloroethylene, C ₂ HCl ₃ |
| • Carbon monoxide, CO | • Hydrogen cyanide, HCN | • Nitric oxide, NO | • Vinyl chloride aka Chloroethene (VCM), C ₂ H ₃ Cl |
| • Chlorine, Cl ₂ | • Hydrogen sulfide, H ₂ S | • Nitrogen dioxide, NO ₂ | • Volatile Organic Compounds, VOCs |
| • Chlorine dioxide, ClO ₂ | • Isobutane, C ₄ H ₁₀ | • Nitrous oxide, N ₂ O | • Water/Dew Point |
| • Combustible Gas | • Isobutylene, C ₄ H ₈ | • Organic solvents | • Xylene, C ₈ H ₁₀ |
| • Dew Point, DP | • Isopropanol, CH ₃ CHOH | • Oxygen, O ₂ | |
| • Ethanol, CH ₃ CH ₂ OH | • Isopropyl alcohol (IPA), C ₃ H ₈ O | | |

*If the gas you need to monitor is not listed, contact ENMET for more details

WARNING: The ProAir 2200, without the oxygen monitoring circuitry, should be used only where there is complete assurance that inert gas cannot be accidentally injected into the breathing air line. Loss of primary power renders continuous gas monitors inoperative. Contact factory for specifications and pricing for backup battery systems compatible with ENMET monitors.