

© 202003-B-USA All Rights Reserved.

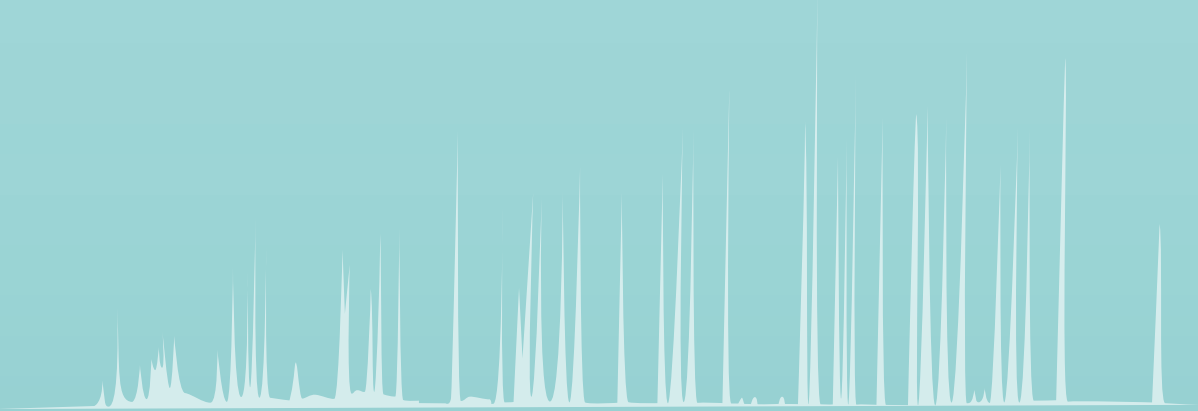

Delivering the Right Results for VOCs



VOCs Analysis Products Catalog

Nutech Instruments, Inc

1825 Summit Ave, Suite 200, Plano, TX 75074

Tel: (972) 480-8908 Fax: (972) 480-8308

Email: info@nutechins.com

www.nutechins.com



Some Global Customers of Nutech



Linde



Maryland State Environmental Lab



NIST (National Institute of Standards and Technology)



SCAQMD (the South Coast Air Quality Management District)



LABICOM s.r.o., Czech Republic



Shenzhen Environment Monitoring Center



About Nutech®

Headquartered in Dallas, Texas, Nutech is a technology leader in volatile organic compounds (VOCs) testing and analysis. For decades, Nutech has been focusing on VOCs sample collection, pretreatment, online monitoring and related technologies. We are one of the very few companies who fully master the technology of 3-stage cryogenic traps preconcentration system around the world.

With its headquarter in Dallas, Texas, Nutech extends its business network to many countries worldwide. Our clients include governmental environment monitoring agencies, 3rd party testing bodies, industrial enterprises, universities and research institutions. Nutech is the sole supplier of preconcentration system of Linde Group and the long term supplier of NIST (National Institute of Standards and Technology). We are the testing device supplier of US EPA TO-15, TO-12A. We also serve customers like Washington River Protection Solutions (WRPS), Restek, Harvard, Environment Canada, Taiwan EPA, HK Government Lab, BP and so on.

Nutech will continue to providing our global customers with the most outstanding products and solutions in the field of VOCs monitoring.

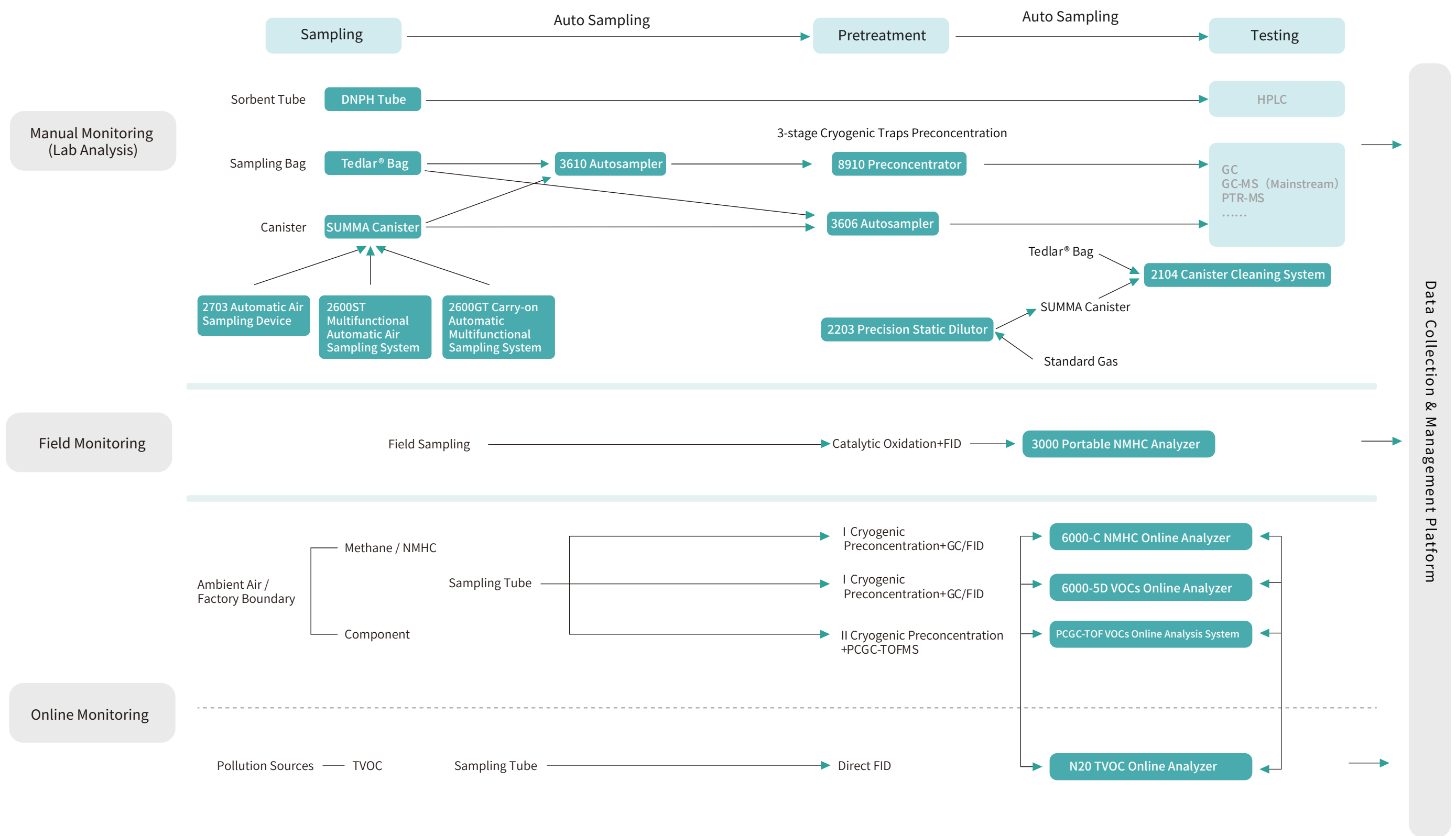

Contents

■ Air Lab Sample Prep Products

7000 NMHC Analyzer	06
8910 Preconcentrator	07
3610 Autosampler	10
3606 Autosampler	11
2104 Canister Cleaning System	12
2203 Precision Static Dilutor	13

■ Air/Gas Sampling Products

2703 Automatic Air Sampling Device	16
2701 Automatic Air Sampling Device	17
2600ST Multifunctional Automatic Air Sampling System	18
2600GT Carry-on Automatic Multifunctional Sampling System	19

■ 3000 Portable NMHC Analyzer

21

■ VOCs Online Analysis Solution

6000-C NMHC Online Analyzer	24
6000-5D VOCs Online Analyzer	25
PCGC-TOF VOCs Online Analysis System	26
N20 TVOC Online Analyzer	28

■ Accessory Products

29

Air Lab Sample Prep Products

EPA TO-14/15
EPA /600-R-98/161

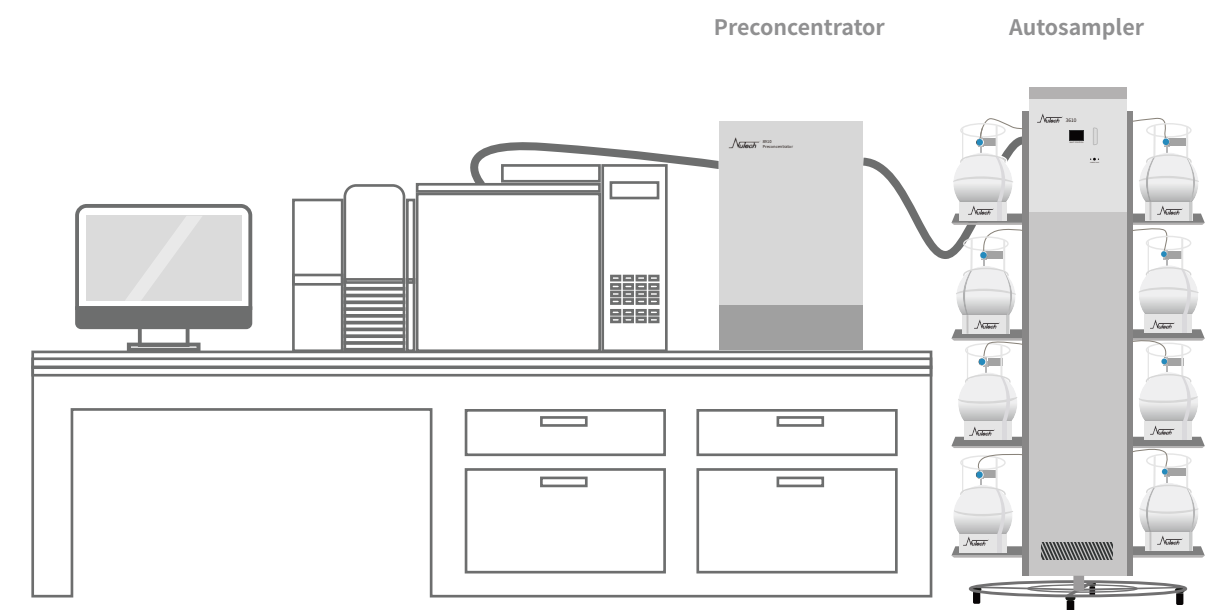

7000 NMHC Analyzer



Applicable to laboratory analysis of methane and non methane total hydrocarbons in ambient air or an industrial plant perimeter (sampled in Summa canisters).

Features

1. The low-temperature preconcentration technology allows for an air sampling volume of 500-1000mL, which reduces the detection limit of NMHC to sub-ppb level (ordinary FID responds to 1 ppm of air organic matter). Detection requirements of low concentration or ultra-low concentration VOC in the ambient air can be readily achieved.
2. The 7000 can effectively remove water and separate non-methane total hydrocarbons and methane by using composite adsorption filter based on Tenax adsorbent and appropriate flow control. Once analyzed by FID detector, the test results are of higher quality than those of general gas chromatography and catalytic oxidation subtraction method.
3. Special FID detector with good response, wide linear range and automatic real-time self check function.
4. The 7000 can seamlessly connect with different specifications (1 / 3 / 6 / 15L Summa canisters). It can expand the sample inlet or select an automatic sampler to obtain automatic and continuous sample analysis of multiple samples with good responses.
5. High precision MFC is used to accurately control flow volume and velocity, ensuring the reliability of test results.
6. Simple operation, avoiding manual operations such as syringe injection and other possible errors. Reduces labor intensity of the analyst, improves work efficiency and ensures the accuracy and precision of the data results.
7. PC control, real-time data acquisition and transmission, automatic recording, storage, and support QA/QC report. With historical data (including atlas) query function, the system can automatically save and restore data if the power is cut off unexpectedly.

Technical Data

Test Method	FID
Measurement Range	0.5 ppb to ppm Level
Analysis Time	<15min
Accuracy	±10%
Precision	RSD<5%
Gas	Ultrapure N ₂ , H ₂ or Air
Maximum Power	1000W
Voltage	110V/60Hz or 220V/50Hz±10%
Operating Environment	Temperature: 10°C~40°C Humidity: 20%~90%RH

8910 Preconcentrator



The 8910 has advanced hardware and software with unique features for the analysis of compounds listed in EPA Methods TO-14 and TO-15. Functionality and longevity were the main goals in the development of Nutech®'s preconcentrator.

Chromatogram

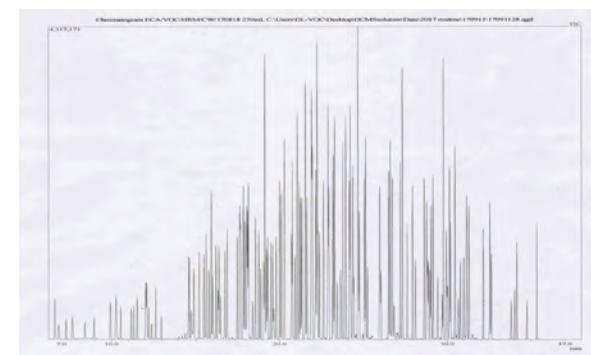

TO-15+PAMS+More, 150 Compounds

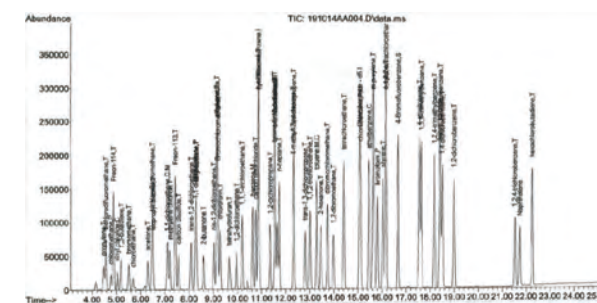

EPA TO-15 Target 67 Compounds

Technical Data

Detection Limit	0.1ppbv						
Loading Range	4-2000ml						
Concentration Ratio	>1000:1						
Temperature control	±2°C Accuracy						
RSD for Most VOC Compounds with A Sample	≤3%						
Heating Rate	10000°C/min						
Maximum Power	2 kW						
Voltage	110V/60Hz or 220V/50Hz±10%						
Three Stage Cryogenic Traps	<table border="0"> <tr> <td>I Glass bead</td> <td>-190°C~250°C</td> </tr> <tr> <td>II Tenax multimedia trap</td> <td>-190°C~250°C</td> </tr> <tr> <td>III Cryofocuser</td> <td>-190°C~250°C</td> </tr> </table>	I Glass bead	-190°C~250°C	II Tenax multimedia trap	-190°C~250°C	III Cryofocuser	-190°C~250°C
I Glass bead	-190°C~250°C						
II Tenax multimedia trap	-190°C~250°C						
III Cryofocuser	-190°C~250°C						

Features

1.Strong Practicability and Wide Application Range

- ① The 8910 uses the classical 3-stage module (two cryogenic traps and one cryofocuser). Coupled with a new generation of advanced H₂O & CO₂ management technology, its preset methods for TO-15, PAMS and sulfide analysis can fully meet the requirements of US EPA methods without any changes or accessories upgrades.
- ② The 8910 creates negative pressure for automatic suction and injection of samples, and has an MFC operating range 5-120mL/min with ±2% accuracy.
- ③ The 8910 has a standard total volume injection range (4-2000 mL). With a quantitative ring injection valve, the minimum injection volume can be as low as 0.2mL, allowing a total volume range to be 4 orders of magnitude.

2.High Sensitivity

- ① The concentration rate is increased more than 1000X, vastly lowering the detection limit of GC or GC-MS.
- ② The advanced temperature control keeps the variation under ±2 °C, assuring stable and accurate analysis.
- ③ The pipeline, valve and other flow path components are inert, durable, and corrosion-resistant. This eliminates unwanted carryover, chemical reactions, minimizes sample contamination, and ensures maximum recovery.

3.High Automatic, Powerful Software

The software is powerful and easy to operate. The system has the ability to perform automatic leak checking, generate reports, and create alarm errors automatically. The software continuously displays operation status, records processed data, and supports QA/QC report printing.

4.Good Compatibility, Powerful Extended Function

The 8910 is highly flexible, allowing users to establish a new analytical method according to their application needs. It is compatible with different types of GCs or GC/MSs in the market. It can be used directly with an instrument, or be coupled with an automatic sampler (3610) for multiple sample analyses.

5.Long-term Stable Operation

- ① Internal structure is optimized in a modular design. Isolation of temperature control module, sensitive components, and the external liquid nitrogen valve effectively avoiding large temperature changes, condensation interference, rust on electronic components. The net result is the long-term stable operation of the instrument.
- ② The small volume trap is designed so that its temperature and liquid nitrogen flow control mode are optimized, keeping liquid nitrogen use down to a minimum.

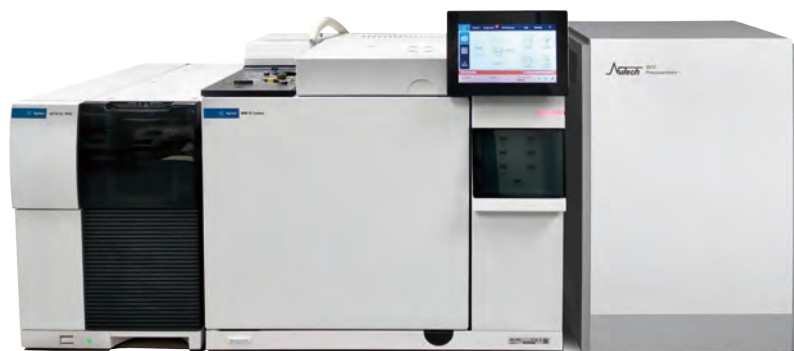

3-Stages H₂O & CO₂ management technology

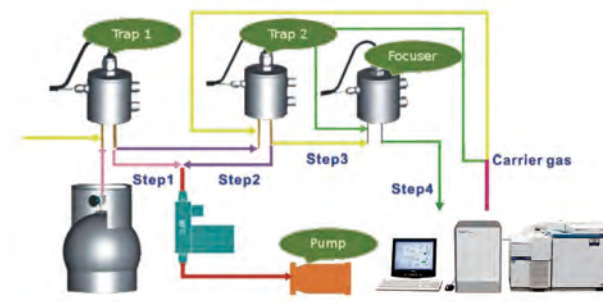

① Control Trap 1 temperature and transfer parameters allow for the partial retention of water within Trap 1 during Trap 1 to Trap 2 transfer.

② Control Trap 2 material property and temperature to avoid water and CO₂ being trapped.

- ③ Focuser Heating Injection control:
- a. N₂ is preheated in the oven.
 - b. Heated N₂ goes through the outside of the focuser column to generate rapid heating rate (Over 10000°C/min).
 - c. Water is partially retained in focuser and can be removed as an optional step at end of GC run.

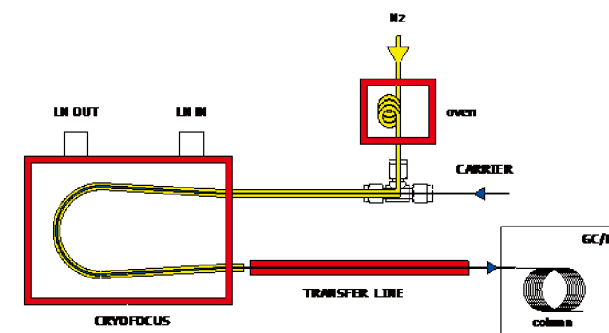

Schematic Diagram

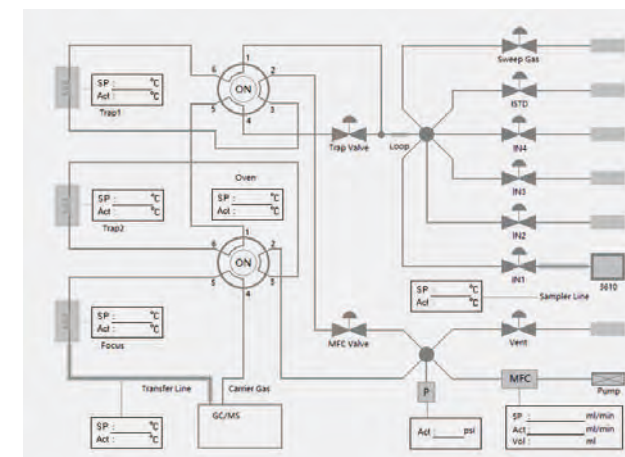

8900DS Preconcentrator (Previous Model)



3610 Autosampler



The 3610 features 16 inlet positions that bring Nutech's automated analysis capabilities to a wide variety of vacuum sampling canisters and Tedlar® bags. The 3610 easily connects to a 8900/8910 Preconcentrator for the automated analysis of VOCs in canisters with EPA TO-14A and TO-15 requirements.

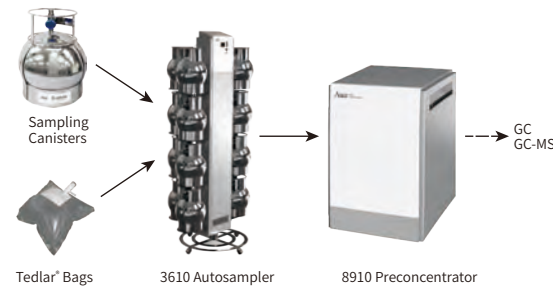

Features

1. Compatibility

Compatible with different types and specifications of sampling canisters on the market. Equipped with Nutech® ETC adapters, it can easily connect with Tedlar® bags, syringes, and sampling bottles.

2. Fully Automatic Sampling

Up to 16 sampling canisters can be analyzed in accordance with EPA Methods TO-14A and TO-15. The automated system can be programmed to set the order, duration, and volume of the sampling sequence. The system can be upgraded to parallel injections with dual detectors to improve efficiency.

3. No pollution

The inner wall of the pipeline is silanized. The system has the functions of automatic leak checking, heating and backflush. The system minimizes contamination and carryover of samples, and ensures sample accuracy and precision.

4. Ergonomic Design

High quality wheels and a stable base allow for easy movement. Canister-support platforms can be closed, saving laboratory space.

3603 Autosampler (Previous Model)



3606 Autosampler



The 3606 holds up to 24 canisters (all sizes) and Tedlar™ bags, with the loop injection valve installed, the autosampler can also be attached directly to a GC or GCMS without the need of the 8910 Preconcentrator when analyzing concentrations exceeding 0.1 ppm. The autosampler is a vertical design which saves valuable laboratory space and makes it easier to add and remove canisters.



Sampling Canisters

Tedlar® Bags

Features

1. Space saving.
2. Easy to add or remove canisters.
3. Flexibility to perform either automated analysis of 24 Silonite® Ror SUMMA canisters in accordance with EPA methods TO-14 and TO-15 with the Model 8910 Preconcentrator or by a direct loop injection to the GC or GC/GCMS.
4. Back-flushing of each line after analysis under software control.
5. Automatic leak-check prior to opening canister valves.



2104 Canister Cleaning System



EPA Methods TO-14 and TO-15 require sampling devices be clean down to the sub-ppbv level. The 2104 is suitable for meeting these requirements. The 2104 is able to clean Summa canisters of various sizes (1/3/6/15L) as well as Tedlar® bags.

Technical Data

Maximum Vacuum	≤10mTorr
Number of Canisters	4 (Customizable)
Heating Mode	Heating belt (Standard), Heating furnace (Optional)
Cleaning Gas	Ultrapure Nitrogen or Zero Air
Voltage	110V/60Hz or 220V/50Hz±10%
Operating Environment	Temperature: -5~50°C; Humidity: 0-95%RH
System Pressure	0~50psi
Maximum Power	1kW
Dimensions	290x455x476mm
Ports	TP/ICP
Operating System	Windows XP/7/8/10

Features

1. Dual pumps (Turbo Pump and Diaphragm Pump) are custom designed, with the final vacuum pressure reaching less than 10mTorr.
2. The 2104 is capable of automatic humidification, leak checking, and easy operation.
3. The 2104 uses dedicated software, capable of multiple rounds of cleaning as well as customized final vacuum or pressure. This automation will allow chemists to focus on other lab work, improving laboratory efficiency.



2108 Oven

Schematic Diagram

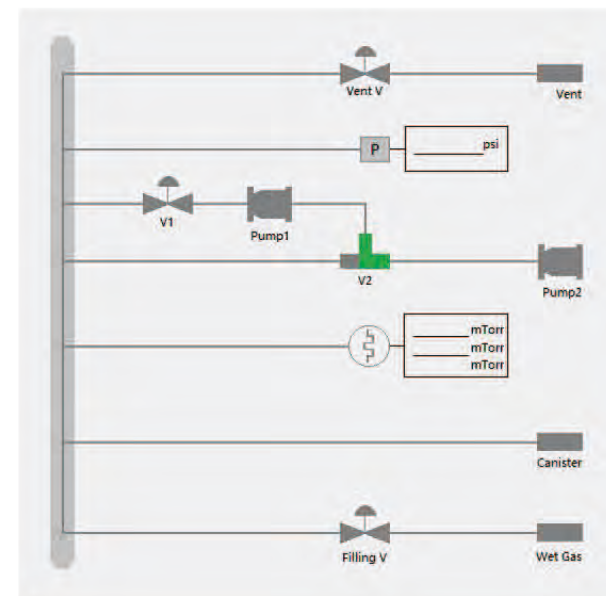

2101DS Canister Cleaning System (Previous Model)



2203 Precision Static Dilutor



It is suitable for diluting high concentration gas standards into low concentration working gas standards, making the process automated and reproducible.

It is suitable for diluting high concentration gas samples to fall within the calibration range of the analytical instrument.

MFC

EPS

Features

1. Using a multi-stage dilution process, the 2203 can reach a maximum dilution factor of 10,000 X, allowing for percent-level analysis on trace-level instruments.
2. The 2203 uses a high precision MFC and pressure sensor for dilution control. Compared with differential pressure instruments, the precision of dilution is higher (<1% for 100 tests).
3. The 2203 is highly efficient with its gas usage. One 110L standard gas can fill over 1,800 6L canisters.
4. The customized software has a high degree of automation. It automatically checks the initial pressure of the sample tank and calculates the final dilution factor based on the final pressure input, and is easy to operate.
5. The 2203 has dedicated lines standard and sample dilutions. The sampling lines and valves are silanized, minimizing the unit's potential contamination of subsequent samples.

Schematic Diagram

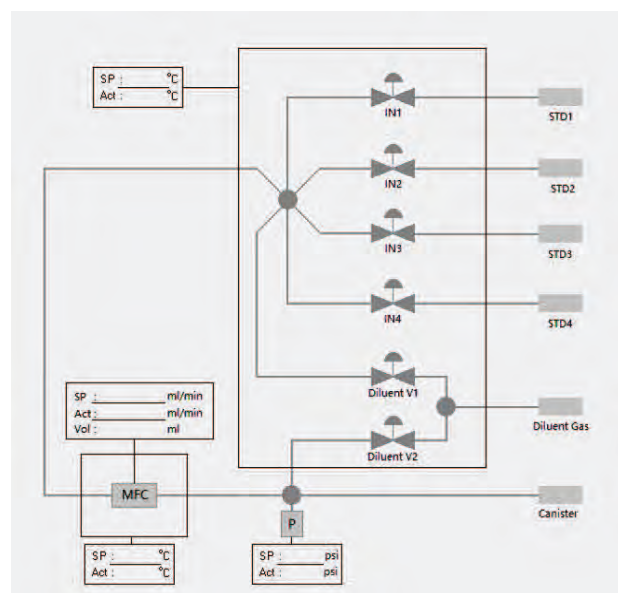

Technical Data

Number of Channels	5 (Customizable)
Precision	$\leq \pm 0.3\%$
Maximum Dilution Times	10000
Gas	Ultrapure Nitrogen or Zero Air
Pressure of Gas	0~35psig
Operating Environment	Temperature: -5~50°C; Humidity: 0-95%RH
Voltage	110V/60Hz or 220V/50Hz $\pm 10\%$
Dimensions	300x360x430mm
Ports	TP/ICP
Operating System	Windows XP/7/8/10

2202A Precision Static Dilutor (Previous Model)



Air/Gas Sampling Products

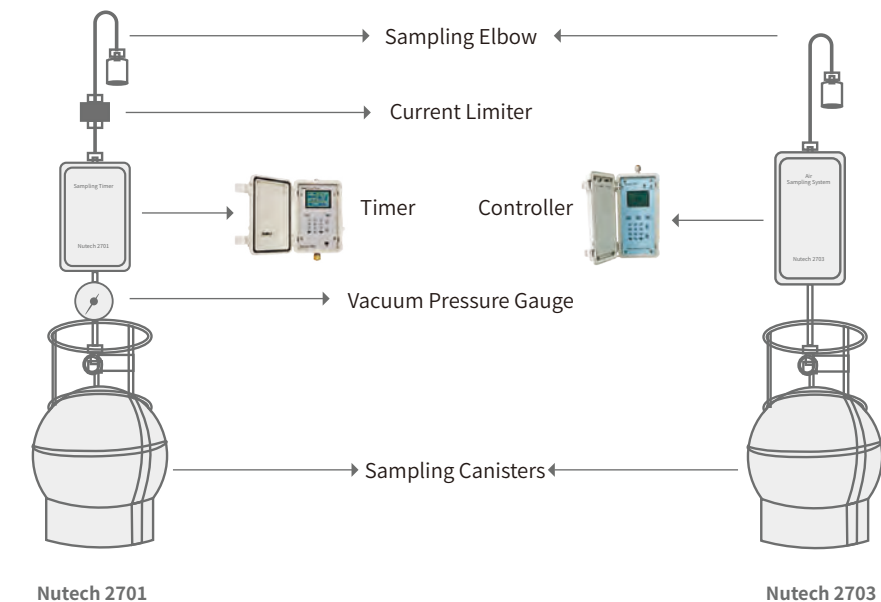

2703 Automatic Air Sampling Device



The 2703 is an ideal product for automated air sampling. It is useful for standard environmental testing, scientific research, and 3rd party monitoring. Features include: an integrated timer, flow control, pressure reading, leak checking, auto QA/QC, a smartphone app with access to full system control.

3.Strong Adaptability

- ① The 2703 has a durable plastic protective cover, and is both water proof and dust proof. It has the option of being upgraded to a stainless steel cover. It is also equipped with a filter kit, allowing for operations in all but extreme weather conditions.
- ② The unit's modular design allows it to be combined with various sampling media, including cartridges, Summa canisters, and Tedlar® bags.

4.High Precision & Minimal Limitations

- ① The 2703's precise flow control uses built-in high precision pressure and flow sensors. The unit avoids the blockage problems and limitations associated with current mechanical air samplers.
- ② Silanized paths minimize the carryover and contamination.

5.Quality Control

With automatic leak detection, the 2703 possesses real-time recording and a visual display of the sampling pressure and flow data. The real-time data and historical data can be queried.



Features

1.Full Automation & Ease of Operation

- ① The 2703 is the latest generation controller, which includes integrated flow control, timing, and pressure reading functions.
- ② The 2703 can be controlled by the on-board PLC, as well as by PC and smartphone. The sampling parameter settings are intuitive and user friendly.
- ③ The wireless control of automated start and stop times reduces time in the field and labor costs.



2.Great Battery Performance



The 2703 features a high-capacity (8700mAh) Li-Ion rechargeable battery and has low power requirements, allowing it to last up to 7 days without recharging.

2701 Automatic Air Sampling Device



- 1. Adopting PLC control and automatically starting sampling program through time setting.
- 2. The 2701 has a stainless steel protective body, and is both water proof and dust proof. It is also equipped with a filter kit, allowing for operations in all but extreme weather conditions.
- 3. The unit's modular design allows it to be combined with various sampling media, including cartridges, Summa canisters, and Tedlar® bags.
- 4. Silanized paths minimize the carryover and contamination.
- 5. The 2701 uses capillary current limiter, which reduces the probability of blockage compared with orifice plate current limiter.

2600ST Multifunctional Automatic Sampling System



The 2600ST is the world's first fully automatic air sampler for collecting air samples in both canister and DNP, an advanced solution in air sampling for environmental testing, scientific research, and 3rd party monitoring.

Technical Data

Number of Sampling Canister	13 (Customizable)
Specification of Sampling Canister	3/6/15L
Number of DNP Cartridges	4 (Customizable)
Number of Channels	4
Voltage	110V/60Hz or 220V/50Hz±10%
Maximum Power	100W
Flow Rate	0-120ml/min
RSD	≤±2%

Schematic Diagram

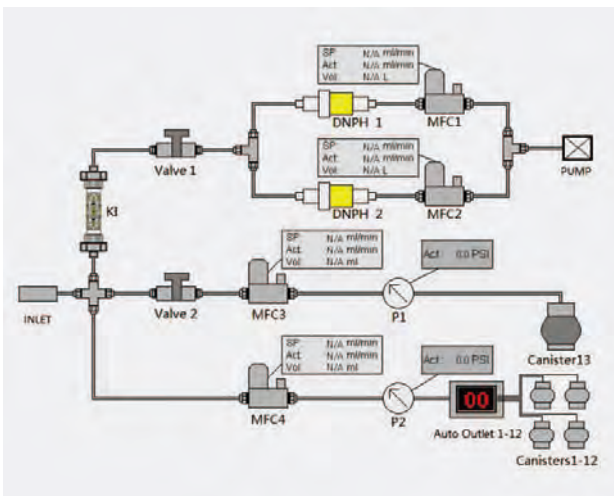

Features

1. Smart and Powerful

- ① Sampling with canister (0-13) and DNP cartridges (0-4 groups).

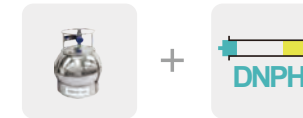

- ② Series or parallel connected in sampling sequences.
- ③ Featuring smartphone, WiFi and pc control which provides threshold control and remote operation.
- ④ Fully automatic during the sampling process.

2. Strong Adaptability

- ① Waterproof and dust-proof design, with all-weather capability.

- ② Automatic leak check before sampling to ensure the validity of sampling.
- ③ Compatible with all types of commercially available canisters.

3. High Precision

- ① Flow rate controlled by MFC, the deviation is less than 2%. Compared to mechanical current limiter, it can avoid blockage completely.
- ② Independent channels and silanized flow paths minimize the cross contamination.
- ③ Supports real-time data logging (including flow rate, pressure and time intervals) and historical data can be queried.

2600GT Carry-on Automatic Multifunctional Sampling System



Features

- The low temperature preconcentration technology increases the air sampling volume to 500-1000mL, lowers the detection limit of NMHC to sub-ppb level (ordinary FID responds to 1 ppm of air VOC), and meets the detection requirements of low or ultra-low concentration air VOC.
- Flow rate controlled by MFC, the deviation is less than 2%. Compared to mechanical current limiter, it can avoid blockage completely.
- The 2600GT can be controlled by PC and smartphone. The sampling parameter settings are intuitive and user friendly. It possesses real-time recording and a visual display of the sampling pressure and flow data.
- Built-in sampling pump with sampling power.
- DC 24V battery, allowing it to last longer than 10 days.
- Sampling box has all-weather waterproof and earthquake-proof functions.

The 2600GT is a VOC sampling product which can bring great convenience to users. It supports both canisters and DNP, and it is convenient to carry.

3000 Portable NMHC Analyzer



3000 Portable NMHC Analyzer

The 3000 is suitable for portable monitoring of TVOC, CH₄ and NMHC in exhaust gas of industrial facilities.



Technical Data

Test Method	Catalytic Oxidation + FID
Measurement Range	0.1 ppb to 10000 ppm
Detection Limit	≤0.07mg/m ³
Conversion Efficiency	≥95%
RSD	≤2%(CH ₄)
Accuracy	±0.2%
Linear Error	±2%(CH ₄)
Recovery Rate of Standard Addition	±20%
Analysis Time	<0.5min
Voltage	DC24V or AC (220±10%) V/ (50±2%) Hz
Operating Environment	Temperature: -20°C~50°C, Humidity: <95%RH

Features

1.Highly integrated and portable

- ① Miniaturized or lightweight components such as miniature hydrogen bottle are used, with the total weight less than 26lb (including catalytic module).



- ② It is equipped with a backpack and a handle, which can be easily transported and put into use.

2.Easy to use

Large capacity battery (45ah) lasts for up to 6 hours without recharging; embedded iPad control, Wi-Fi communication, and a user-friendly interface.Users can control the instrument within 33ft of the site through the preset software iPad. Data results can also be downloaded and read at a later date.

3.High test efficiency

- ① The preheating time of the system is less than 5min.
- ② The new catalyst is used with high conversion efficiency ($\geq 95\%$), fast gas path cleaning speed, which supports continuous and uninterrupted measurement.
- ③ Double FID and automatic flow path, with analysis time < 2min.

4.Controllable process and accurate results

- ① Minimal loss of samples under high temperature (tracing over 120 °C) and humidity.
- ② The sampling tube is resistant to high temperature and corrosion, and contains filtering device to effectively filter particles and avoid sample pollution and adsorption.
- ③ The high-precision EPC and FID detectors independently developed are used to control the flow accurately.

5.Powerful data processing functions

Data file automatic recording and storage, historical data query, reprocessing and printing functions; display and time label functions; data report functions.

6.Expandability

- ① The user can adapt the heat tracing pipeline as required.
- ② The standard gas cylinder and hydrogen gas cylinder can be reused, and the consumables such as activated carbon purification pipe and ignition wire in FID can be replaced.

Software Interface

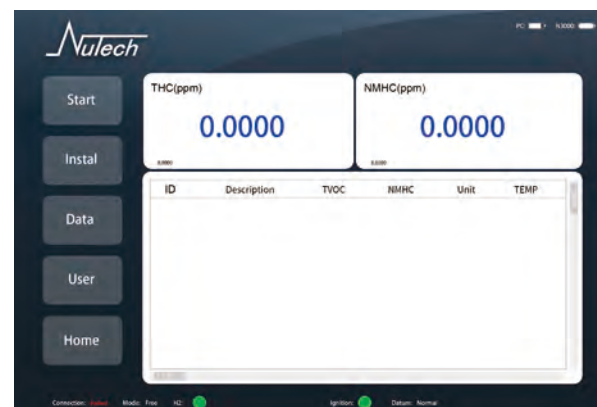

VOCs OnLine Analysis Solution

EPA-25A

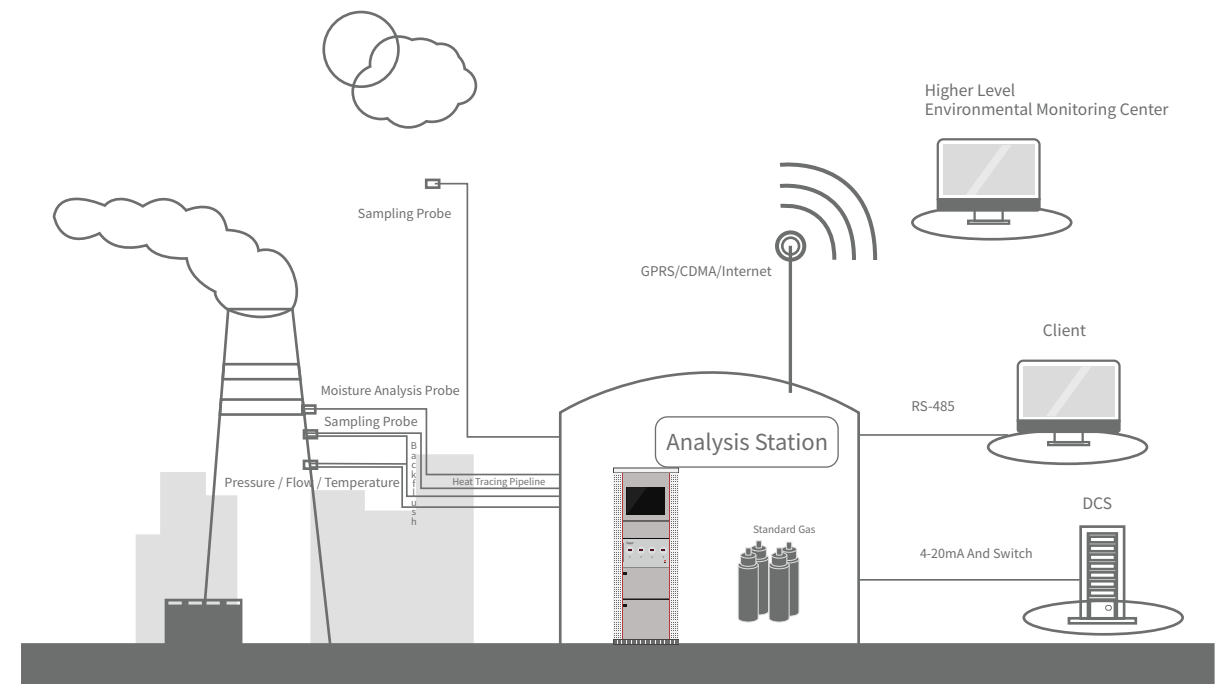

6000-C NMHC Online Analyzer



The 6000C is designed for online monitoring of methane/non-methane total hydrocarbons in ambient air and industrial plant perimeters. It continuously takes air samples, analyzes, and reports TVOC in a short time. It can be integrated into an air quality or environmental data system and give instant air quality results.

Technical Data

Test Method	FID
Measurement Range	0.1 ppb to ppm Level
Analysis Time	<15min
Accuracy	±10%
Precision	RSD<5%
Gas	Ultrapure N ₂ , H ₂ or Air
Voltage	110V/60Hz or 220V/50Hz±10%
Operating Environment	Temperature: 10°C~40°C; Humidity: 20-90%RH
Maximum Power	1kW

Schematic Diagram

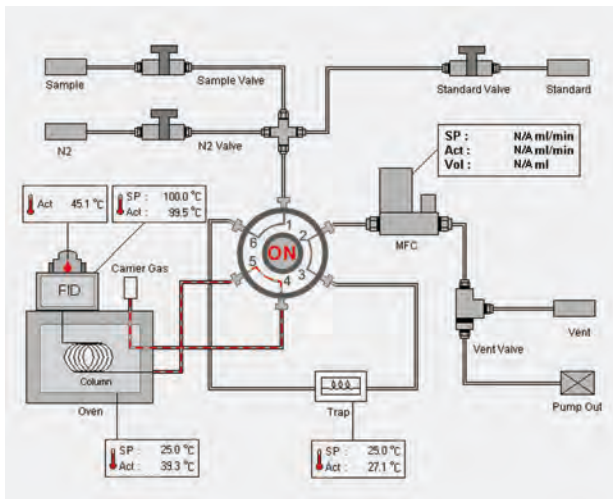

Features

1. The low temperature preconcentration technology increases the air sampling volume to 500-1000mL, lowers the detection limit of NMHC to sub-ppb level (ordinary FID responds to 1 ppm of air VOC), and meets the detection requirements of low or ultra-low concentration air VOC.
2. The 6000-C effectively removes the water in samples and separates non-methane total hydrocarbons and methane by using composite adsorption filters, based on Tenax adsorbent and appropriate flow control. The treated sample can then be directly analyzed by FID. The test results have better quality than those of general gas chromatography and catalytic oxidation subtraction methods.
3. With FID detector, it has good response, wide linear range, and automatic real-time self-test function.
4. Uses an MFC to accurately control the flow rate, ensuring the accuracy of test results.
5. PC control, real-time data acquisition and transmission, automatic recording, storage, and support of QA/QC reports. With historical data (including atlas) query function, the system can automatically save and restore data if the power is cut off unexpectedly.

6000-5D VOCs Online Analyzer



The 6000-5D is suitable for continuous real-time online monitoring of C₂~C₁₂ volatile organic compounds in ambient air and/or fence line. The unit is capable of covering 108 of PAMS and EPA TO-15 target compounds and as well as non-accredited compounds (including some aldehydes and ketones). It is ideal for use with monitoring ambient air quality around industrial plant perimeters or near chemical industry parks.

Technical Data

Test Method	FID
Measurement Range	0.1 ppb to ppm Level
Maximum Temperature Rise Rate	1000°C/min
Adsorption/ Desorption Temperature	-10°C~350°C (Adjustable)
Sampling Rate	5~120ml/min (Adjustable)
Accuracy	±10%
Precision	RSD<5%
Gas	Ultrapure N ₂ , H ₂ or Air
Data Interface	R~232, Ethernet Interface
Voltage	110V/60Hz or 220V/50Hz±10%
Operating Environment	Temperature: 10°C~40°C; Humidity: 20-90%RH
Maximum Power	3.5kW

Schematic Diagram

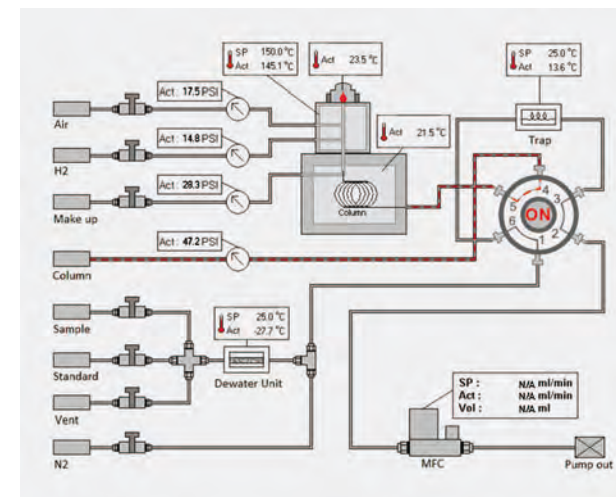

Features

1. Nutech's innovative and improved separation column was used to meet the separation and analysis needs of 108+ target compounds, including PAMS, EPA TO-15, and some aldehydes and ketones.
2. The low-temperature preconcentration technology greatly improves the detection limit, meets the detection requirements of VOC components in low or ultra-low concentration air, and can report the concentration of TVOC at the same time.
3. The application of the latest generation of advanced technology enables the system to maximize the separation of moisture in samples, avoiding FID quenching.
4. With an FID detector, the instrument achieves good responses, a wide linear range, and an automatic real-time self-test function.
5. Uses an MFC to accurately control the flow rate and ensure the accuracy of test results.
6. PC control, real-time data acquisition and transmission, automatic recording, storage, and support of QA/QC reports. With historical data (including atlas) query function, the system can automatically save and restore data if the power is cut off unexpectedly.

PCGC-TOF VOCs Online Analysis System



The PCGC-TOF is suitable for continuous real-time online monitoring of $C_2 \sim C_{12}$ volatile organic compounds. The unit is capable of covering PAMS and EPA TO-15 target compounds. It is ideal for use with monitoring ambient air quality around industrial plant perimeters or near chemical industry parks.

Technical Data

Measurement Range	0.1~1000ppb
Linearity	RSD< 5% (More than 90% Compounds)
Precision	RSD<3%
Accuracy	±10%
Temperature Control Accuracy	±2%
Maximum Heating Rate	350°C/min
Sampling Rate	5~120ml/min
Voltage	110V/60Hz or 220V/50Hz±10%
Operating Environment	Temperature: 10°C~40°C; Humidity: 20-90%RH
Maximum Power	0.6kW

Features

1. On the basis of low temperature preconcentration and chromatography separation technology, flight mass spectrometry technology is introduced to solve the problem of difficult separation of some target compounds. It can also enhance the qualitative and quantitative capabilities, and improve the accuracy/stability of the instrument.
2. The mass spectrometry detector is used for the identification of compounds not found in the standard calibration mix.
3. PC control, built-in user login, equipment safety alarm, operation log, real-time data collection, transmission, automatic recording and storage, and data support in the form of reports, historical data, Atlas query and power-off memory.

Chromatogram

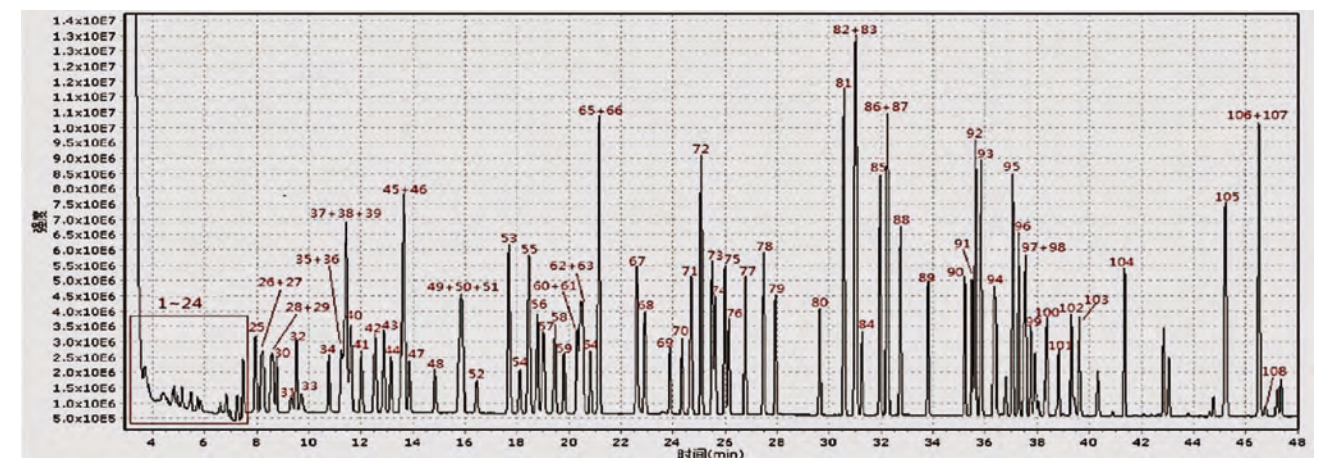

N20 TVOC Online Analyzer



The N20 is suitable for continuous and real-time online monitoring of total volatile organic compounds (TVOCs). Likely pollution sources include petrochemical, chemical, cement building materials, rubber products, biopharmaceutical, industrial coating, packaging and printing, electronic information, synthetic materials, textile printing and dyeing, solid/hazardous waste disposal, and landfills.

Technical Data

Test Method	FID
Measurement Range	0.1 ppb to ppm Level
Linearity	RSD< 10%
Repeatability	RSD< 5%
Stability	RSD< 5%
Drift	±5% (F.S)
Voltage	110V/60Hz or 220V/50Hz±10%
Operating Environment	Temperature: 10°C~40°C; Humidity: 20-90%RH
Maximum Power	0.6kW

Features

1. Real-time on-line, Fast response

Direct FID detection without chromatographic column, quantitative tube or quantitative ring, instantaneous (0.1s) response.

2. Strong anti-interference ability

- ① Using reliable internal heating technology, the gas is discharged from the exhaust port until it is detected by FID. The process of heat tracing can avoid condensation and water blockage.
- ② Use of a high-strength filter device offers protection on multiple levels. It avoids interference of fine particulate matter, acids/bases, water, carbon dioxide and other compounds commonly found in industrial exhaust gas.

3. Mature Technology and Stable Data

With FID detector, all volatile organic compounds have a good response, mature and reliable technology, wide linear range and stable data, meet with EPA-25A.

4. High Automatic

The instrument can automatically select measuring range, ignition, fuel shutdown, flameout indication, automatic calibration and zero adjustment by program control.

5. Extensibility

- ① Single or double channels can be selected according to the working conditions (that is, one instrument can monitor two pollution sources online at the same time). When the physical distance of flue gas is relatively close, the design of double channels can effectively reduce user costs.
- ② If equipped with sampling pipeline, zero/hydrogen generator, controller, etc., the on-line monitoring system can be formed and seamlessly docked with the upper data management system.

Accessory Products



Sampling Canister

Type TO-Can™ or SilcoCan™

Specifications 0.45/1/3/6/15L

Canisters are used for the collection of TO-14 and TO-15 compounds, as well as all other air samples. The canisters are the most important part of the whole air VOC analysis.



Standard Gas

Type TO14, TO15, PAMS, IS/SS

Specifications 1.0PPM, 6A, 1700psi

Traceable to NIST, quality assurance, and configurable according to requirements.



Tedlar® Bag

Specifications 0.5/1.0/3.0/5.0/10.0L

DuPont PVF material, excellent chemical resistance, solubility and pollution resistance, strong acid and alkali resistance, normal temperature, not affected by conventional solvents, suitable for industrial waste gas sampling.

Capsule Soil Sampler



The easiest tool for collecting, storing and transferring undisturbed soil of 5g and below, in accordance with the US EPA 5035 method.



Assemble the Sampler



Collect Sample



Eject Sample into the Sample Container

Syringe Soil Sampler



The most widely used tool for collecting and transferring 5g or 10g of undisturbed soil, in accordance with the US EPA 5035 method.



Assemble the Sampler



Collect Sample



Eject Sample into the Sample Container

Our Partners



Linde



NIST



RESTEK



EPA



WRPS



AECOM



Harvard



FOXCONN



SMIC



BP



Panasonic



LONZA

.....

