

# NANOPARTICLE EMISSIONS TESTER MODEL 3795

PORTABLE, ACCURATE AND  
REGULATORY-COMPLIANT



The TSI Nanoparticle Emission Tester (NPET) Model 3795 is a portable, accurate instrument capable of measuring total solid particle number emissions from a variety of diesel-powered sources, including construction machinery, buses, stationary gensets, and more. Featuring a robust, user-friendly design, the NPET can be used in the field by researchers, regulatory inspectors, and maintenance personnel alike.

## Features and Benefits

- + Direct measurement of particle number concentration using proven Condensation Particle Counter (CPC) technology
- + Sampling probe with integrated dilution to measure concentrations up to 5,000,000 particles/cm<sup>3</sup>
- + Built-in catalytic stripper for volatile particle removal
- + Wide environmental operating range
  - -10° C to 40° C
  - 0 to 3,000 m
- + Two measurement modes:
  - General: Real-time data logging for research
  - Official: Swiss Regulation SR 941.242 certification in less than one minute

## Applications

- + In-use diesel machinery compliance certification
- + Exhaust after treatment inspection and maintenance programs
- + Diesel Particulate Filter (DPF) retrofit programs
- + Fleet emissions profiling
- + Combustion emissions research



UNDERSTANDING, ACCELERATED

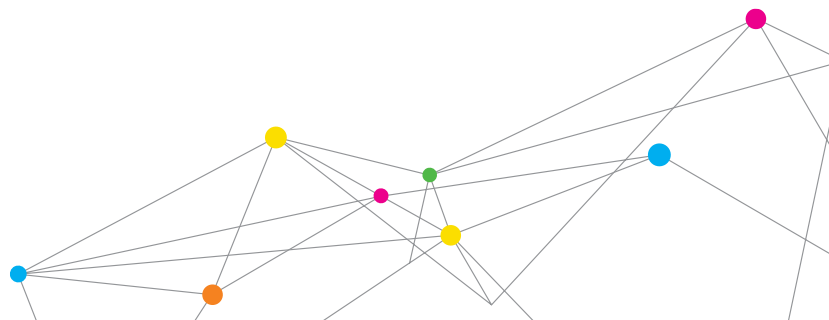

# PORTABLE, ACCURATE, SOLID PARTICLE NUMBER (PN) MEASUREMENTS

## Particle Number Concentration

As manufacturers develop cleaner combustion and after-treatment technologies to meet emission standards like Euro 5/6 or Tier 4, it is becoming increasingly difficult to measure emissions concentrations on a mass basis. Solid particle number concentration is a proven and globally accepted metric for researchers and regulators to determine compliance of various combustion sources with emissions limits.

## Portability

The Nanoparticle Emissions Tester is a rugged, mobile instrument conveniently equipped with a clamp-on sample probe with built in dilution, and a software package optimized for Microsoft® Windows® 8 tablet allowing for ease of use in laboratory and field testing applications of on-road and off-road equipment.

## Official Certification Testing

The Nanoparticle Emissions Tester fully meets Swiss Regulation 941.242 for the periodic certification of diesel-powered machinery equipped with a DPF.

## Solid Particle Measurements

Sampling from combustion sources is often challenging due to the presence of volatile material. Volatile components are extremely sensitive to sampling conditions and can grow existing particles and form new particles through condensation. By evaporating and oxidizing volatile components and particles, the NPET Model 3795 measures only the remaining solid particles.

## A Sophisticated Instrument in a Simple Package

The Nanoparticle Emissions Tester combines a traditionally complex system of components into a portable, robust measurement tool. The five key design components include:

- Sampling probe:** A stainless steel sample probe with built-in diluter and removable clamp allows for easy measurement of high concentration particle number emissions directly from the tailpipe.
- Preconditioner:** A 1.0  $\mu\text{m}$  cyclone removes large particles while a water trap removes moisture from the exhaust gas sample.
- Recirculating dilution flow conditioner:** A silica desiccant dryer and two high capacity HEPA filters efficiently dry and clean the recirculating dilution flow for continuous operation with no loss of accuracy.
- Volatile particle remover:** A catalytic stripper heated to 350° C evaporates, and oxidizes volatile components to remove them from the sample stream.
- Particle counter:** An isopropanol-based CPC provides accurate, direct measurement of particle number emissions at high and low concentrations over the entire range of temperature and altitude conditions.

## NANOPARTICLE EMISSION TESTER

### Operating Principle

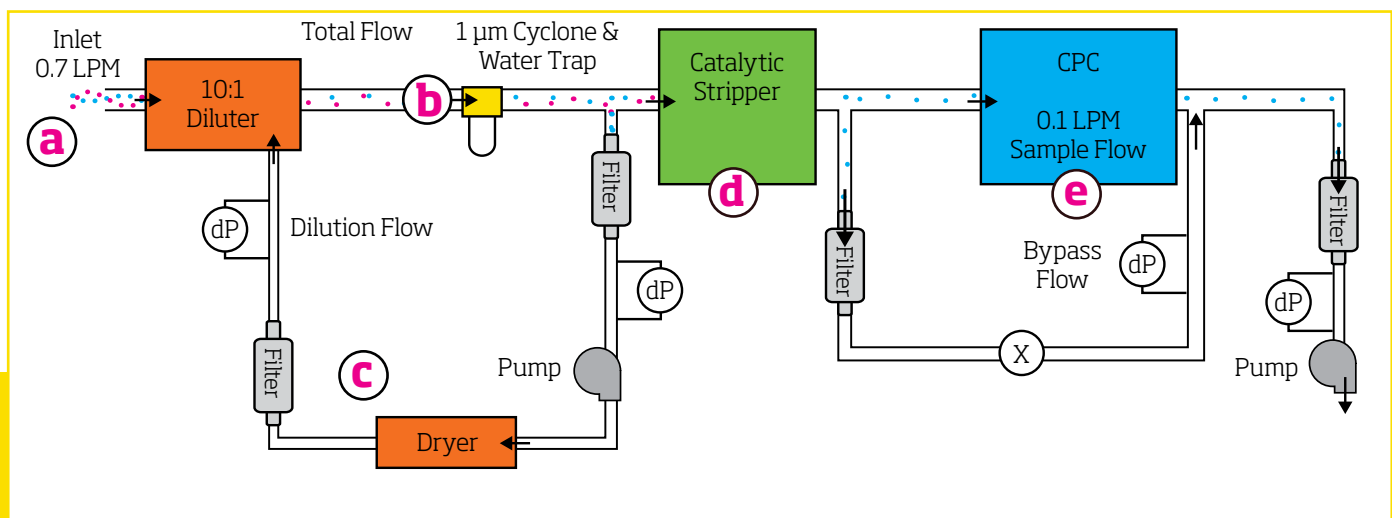

## Easy-to-Use Software Optimized for Touch Screen Operation

One instrument, two modes of operation (shown below).

### General Purpose Test Mode

- + 1Hz data collection
- + Live strip chart of total solid particle number concentration
- + Live cumulative statistics (max, min, standard deviation, etc.)
- + User selectable sample duration
- + Ambient condition monitoring (temperature, pressure, and relative humidity)

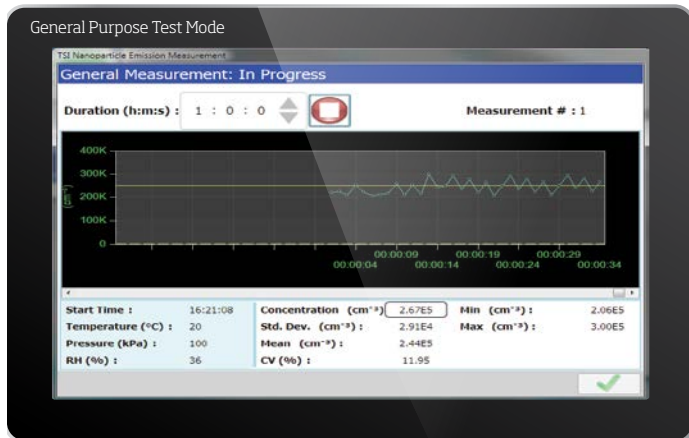

### Official Swiss Test Mode

- + Compliant with SR 941.242
- + Easy-to-follow operator prompts
- + Automated data collection according to SR 941.242 protocol
- + Generation and onboard storage of official report in locked PDF format
- + Results in less than one minute

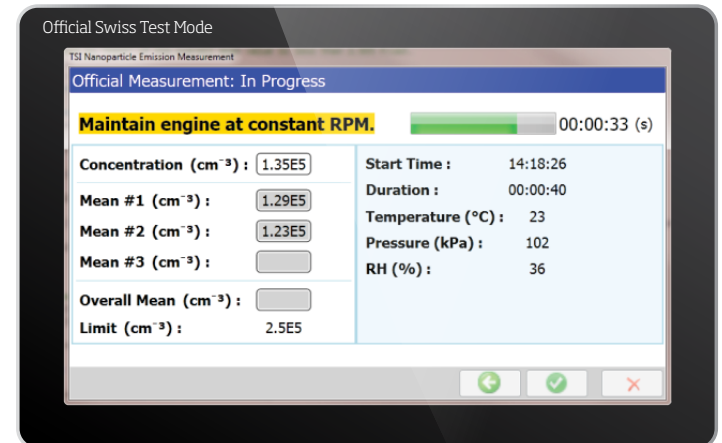

## SPECIFICATIONS

### NANOPARTICLE EMISSIONS TESTER MODEL 3795

|   |   |
|---|---|
| <b>Particle Size Range</b>  |   |
| Detection Efficiency  | <50% at 23 nm >50% at 41 nm                                     |
| Max. Detectable Particle  | Limited to 1 µm by inlet cyclone                                |
| <b>Particle Concentration Range</b>   |   |
| Single Particle Counting (Nominal 10:1 Dilution)  | 1,000 to 5 x 10 <sup>6</sup> particles/cm <sup>3</sup>          |
| <b>Particle Concentration Accuracy</b>  |   |
| ±10% compared to standard   |   |
| <b>Response Time</b>  |   |
| T <sub>10%-90%</sub> and T <sub>90%-10%</sub>   | 4±0.5 seconds   |
| T <sub>0%-90%</sub>   | 8±0.5 seconds   |
| <b>Flow</b>   |   |
| Instrument Inlet Flow Rate  | 0.7 L/min (nominal)   |
| CPC Aerosol Flow Rate   | 0.1 L/min (nominal)   |
| CPC Bypass Flow Rate  | 0.6 L/min (nominal)   |
| <b>Condensing Liquid</b>  |   |
| Working Fluid   | 99.5%+ reagent-grade isopropyl alcohol                          |
| Filling System  | Rechargeable wick   |
| Sample Time Per Fill  | 4 hours   |
| <b>Catalytic Stripper</b>   |   |
| Temperature   | 350° C  |
| Volatile Particle Removal Efficiency  | >99% of 30 nm, NMD polydisperse C <sub>40</sub> H <sub>82</sub> |
| <b>Aerosol Medium</b>   |   |
| Designed to sample high temperature (up to 300° C), corrosive (NO <sub>x</sub> , HC, H <sub>2</sub> O, H <sub>2</sub> SO <sub>4</sub> ) engine exhaust gas. |   |
| <b>Environmental Operating Conditions (ambient)</b>   |   |
| Temperature   | -10 to 40° C  |
| Pressure  | 70 kPa to 106 kPa   |

|  |   |
|--|---|
| <b>Power Requirement</b>   |   |
| 100 to 240 VAC, 50/60 Hz, 100 W nominal, 200 W peak  |   |
| <b>Communications</b>  |   |
| Ethernet   | 8-wire RJ-45 jack, 10/100 BASE-T, TCP/IP                                      |
| <b>Software</b>  |   |
| TSI Nanoparticle Emissions Tester Software. Microsoft® Windows® 7 (32 or 64 bit) compatible; Windows 8 optimized for touchscreen |   |
| <b>Sampling Interval</b>   |   |
| Official Test Mode   | 10 Hz   |
| General Sampling Mode  | 1 Hz  |
| <b>Calibration/Service Interval</b>  |   |
| Recommended annually   |   |
| <b>Physical Features</b>   |   |
| Front Panel  | Water trap, cyclone, probe connections (sample inlet and dilution air outlet) |
| Rear Panel   | Power connector, Ethernet port, wick port                                     |
| <b>Dimensions (H x W x D)</b>  |   |
| 10.2" x 13" x 22.4" (26 cm x 33 cm x 57 cm)  |   |
| <b>Weight</b>  |   |
| 13.1 kg (28.9 lbs.)  |   |
| <b>Consumables</b>   |   |
| HEPA Filters (2x), Cobalt-free silica desiccant cartridge, 99.5%+ reagent-grade isopropyl alcohol                                |   |
| <b>Optional Accessories</b>  |   |
| 3795-Tab   | Windows® 8 tablet with ruggedized case and ethernet dongle                    |
| 1602051  | HEPA Filter   |
| 6008033  | Dryer cartridge   |
| 8016   | 30 ml isopropyl alcohol bottles (16)  |

TSI and the TSI logo are registered trademarks of TSI Incorporated.

Windows is a registered trademark of Microsoft Corporation in the United States and/or other countries.



UNDERSTANDING, ACCELERATED

TSI Incorporated - Visit our website [www.tsi.com](http://www.tsi.com) for more information.

|                |                               |                  |                              |
|----------------|-------------------------------|------------------|------------------------------|
| <b>USA</b>     | <b>Tel:</b> +1 800 874 2811   | <b>India</b>     | <b>Tel:</b> +91 80 67877200  |
| <b>UK</b>      | <b>Tel:</b> +44 149 4 459200  | <b>China</b>     | <b>Tel:</b> +86 10 8219 7688 |
| <b>France</b>  | <b>Tel:</b> +33 4 91 11 87 64 | <b>Singapore</b> | <b>Tel:</b> +65 6595 6388    |
| <b>Germany</b> | <b>Tel:</b> +49 241 523030    |                  |                              |